

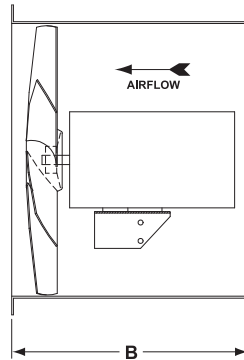

# Direct Drive Tubeaxial Fan Model HDD

Model HDD fan is a direct drive, tubeaxial exhauster with the motor in the airstream. Capacities up to 14,792 CFM and up to 3/4 inch static pressure. The compact design provides easy installation with ducted ventilation systems. The HDD is designed to operate in any position and is furnished with mounting flanges on both ends for easy installation.

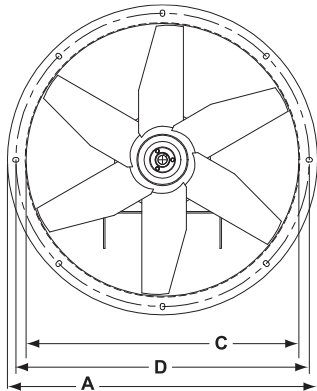
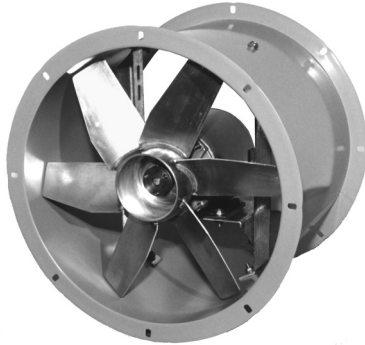

## Construction Features

### Housing

- Constructed of heavy gauge rolled steel
- Rolled flange at each end for ease of mounting
- Standard charcoal baked enamel finish provides a tough durable surface

### Aluminum Propeller

- Heavy duty, all welded aluminum construction
- Precision balanced circular-arc blades for high airflow capacity
- Explosion proof switch separate when explosion proof motors are selected

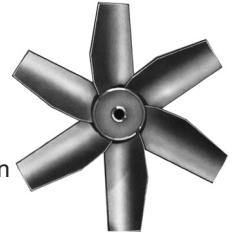

### Disconnect Switch

- All units are equipped with a factory wired disconnect switch

### Motors

- Continuous duty motors located in the airstream
- Motors shipped mounted to the fan

## Options/Accessories

- Coatings
- 2 Speed Switch
- Solid State Speed Controller
- Companion Flange
- Mounting Base
- Guard

DIMENSIONS					
Fan Model	A	B	C	D	Est. Unit Wt.
HDD12	14.56	14.00	12.22	13.44	35
HDD16	18.50	14.00	16.10	17.50	47
HDD18	21.00	16.00	18.48	19.88	54
HDD21	23.88	16.00	21.25	22.56	66
HDD24	26.88	18.00	24.44	25.75	76
HDD30	33.64	21.00	30.60	32.25	98

Dimensions are shown in inches.

For more information on this product contact your Sales Support.

PERFORMANCE DATA										
Fan Model	HP	RPM	Max. BHP	Sones @ 0.0"	CFM vs. Static Pressure					
					.000"	.125"	.250"	.375"	.500"	.625"
HDD12E	1/4	1750	0.14	17.1	1627	1465	1182			
		1160	0.04	9.9	1079					
HDD16F	1/3	1750	0.36	22	2763	2595	2388			
		1160	0.10	14.9	1832	1530				
HDD18G	1/2	1750	0.52	25	3938	3724	3521	3323	3058	
		1160	0.14	14.1	2610	2299	1807			
HDD18H	3/4	1750	0.80	29	4670	4436	4198	3947	3653	
		1160	0.21	16.7	3095	2738	2266			
HDD21J	1	1750	1.10	27	6193	5970	5738	5489	5211	4891
		1160	0.33	14.3	4105	3760	3341	2167		
HDD24J	1	1160	1.02	20	8555	8105	7613	6998		
HDD30M	3	1160	3.06	29	14792	14208	13624	13036	12419	11681

Performance certified is for Installation Type A - Free Inlet, Free Outlet. The sound ratings shown are loudness values in hemispherical sones at 1.5 m (5ft) in a hemispherical free field calculated per AMCA Standard 301. Values shown are for Installation Type A: Free inlet hemispherical sone levels. Performance ratings do not include the effects of appurtenances (accessories).

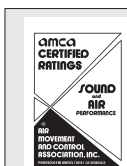

Acme Engineering & Manufacturing Corporation certifies that the models shown herein are licensed to bear the AMCA seal. The ratings shown are based on tests and procedures performed in accordance with AMCA Publication 211 and AMCA Publication 311 and comply with the requirements of the AMCA Certified Ratings Program.



U.L. 705 Listed

Consult your Acme representative for availability.