

CBFI SERIES

Inline Exhausters

Ideal for offices, conference rooms, public restrooms and more.



CBF150/CBF300
INLINE
EXHAUSTER

CBF700
INLINE
EXHAUSTER

CBF1150
INLINE
EXHAUSTER

FEATURES

- Available in 4 sizes with CFM's ranging from 66 to 1200 CFM.
- EC motor with forward curved wheel.
- Built in speed control.
- Low profile, quiet and energy efficient, inline exhauster.

PERFORMANCE SPECIFICATIONS

MODEL	CFM							Sones @ 1/8" SP	Watts	Amps
	0	0.125	0.25	0.375	0.5	0.75	1			
CBF1150	149	130	114	93	66	-	-	1.5	14	0.22
CBF300	306	278	262	239	219	180	140	2.9	47	0.67
CBF700	660	634	607	574	498	380	239	4.7	218	1.7
CBF1500	1235	1153	1068	964	718	229	-	8.4	264	4.9

EC motor with 0 to 10V speed control to adjust RPM to achieve desired performance - keep control above 0.9V otherwise motor turns off!

CBF1150 1.5 sones @ nominal 1/8" static and 10V

SPEED CONTROL VOLTS	CFM						
	0	0.125	0.25	0.375	0.5	0.75	1
10	149	130	114	94	66	-	-
7.5	145	125	110	90	62	-	-
5	140	120	105	87	60	-	-
2.5	119	94	73	32	-	-	-

CBF300 2.9 sones @ nominal 1/8" static and 10V

SPEED CONTROL VOLTS	CFM						
	0	0.125	0.25	0.375	0.5	0.75	1
10	306	278	262	239	219	180	140
7.5	303	275	260	237	217	179	138
5	227	193	171	143	110	57	-
2.5	143	95	55	-	-	-	-

CBF700 4.7 sones @ nominal 1/8" static and 10V

SPEED CONTROL VOLTS	CFM						
	0	0.125	0.25	0.375	0.5	0.75	1
10	660	634	607	574	498	380	239
7.5	627	602	577	545	473	361	227
5	583	560	537	507	440	336	211
3.25	531	510	489	461	400	306	192
2.5	478	459	440	415	360	275	173
1.75	430	413	396	374	324	248	156

CBF1500 8.4 sones @ nominal 1/8" static and 10V

SPEED CONTROL VOLTS	CFM						
	0	0.125	0.25	0.375	0.5	0.75	1
10	1235	1153	1068	964	718	229	-
7.5	1110	1035	961	572	-	-	-
5	999	931	865	-	-	-	-

DIMENSIONS

CBF1150/CBF300
INLINE
EXHAUSTER

DUCT DIAMETER
CBF1150 - 6"
CBF300 - 8"

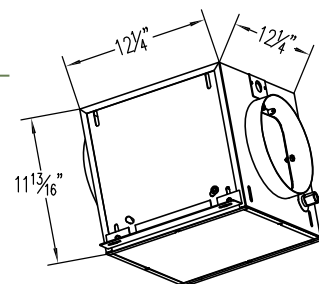

CBF700
INLINE
EXHAUSTER

DUCT DIAMETER
CBF700 - 18 1/2" x 4 1/2"

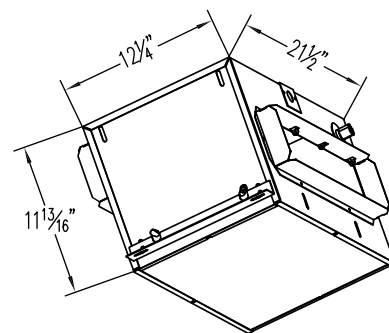

CBF1500
INLINE EXHAUSTER

DUCT DIAMETER
CBF1500 - 13 1/4" x 8 1/4"

